

STROJNÍ ZÁVITNÍKY "METRICKÉ" PRŮCHOZÍ S LAMAČEM DIN371 - LEVÉ

ocel do 850 N/mm², bronz 700 N/mm², hliník Si < 10% - 600 N/mm²

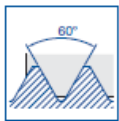

Material		Vc
Grupo	Sub.	5% Co
1	1.1	6-10
5	5.1	5-8
6	6.1	15-35
	6.2	14-20

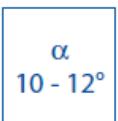
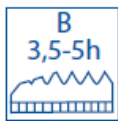
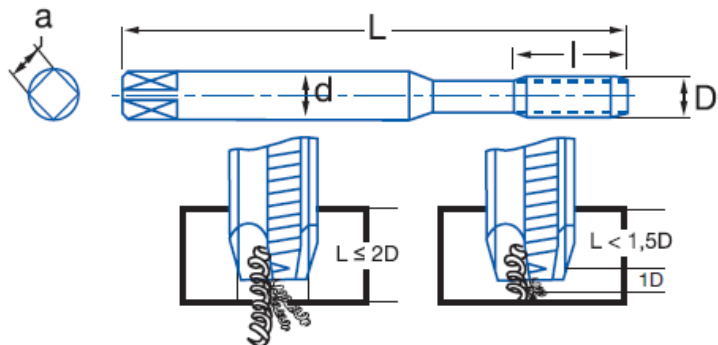

Vc= m/min.

Označení	M	P	L mm	l mm	d mm	a mm	Z	CZK/ks bez DPH
3101-M2	M2	0,4	45	9	2,8	2,1	3	631
3101-M3	M3	0,5	56	11	3,5	2,7	3	359
3101-M4	M4	0,7	63	13	4,5	3,4	3	378
3101-M5	M5	0,8	70	16	6	4,9	3	378
3101-M6	M6	1	80	19	6	4,9	3	416
3101-M7	M7	1	80	19	7	5,5	3	658
3101-M8	M8	1,25	90	22	8	6,2	3	465
3101-M10	M10	1,5	100	24	10	8	3	572

STROJNÍ ZÁVITNÍKY "METRICKÉ" PRŮCHOZÍ S LAMAČEM DIN376 - LEVÉ

ocel do 850 N/mm², bronz 700 N/mm², hliník Si < 10% - 600 N/mm²

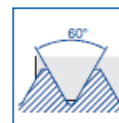
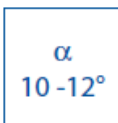
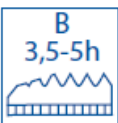

Material		Vc
Grupo	Sub.	5% Co
1	1.1	6-10
5	5.1	5-8
6	6.1	15-35
	6.2	14-20

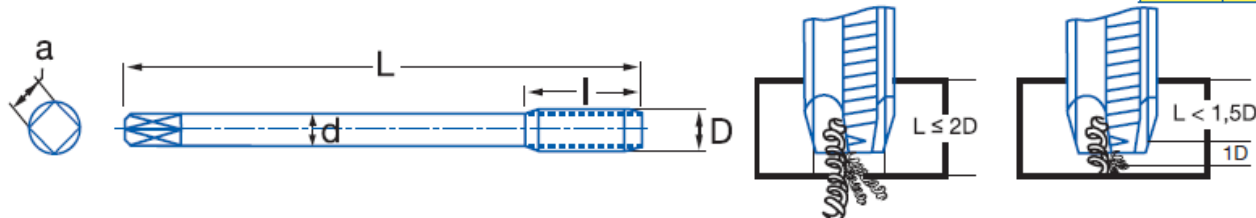

Vc= m/min.

Označení	M	P	L mm	l mm	d mm	a mm	Z	CZK/ks bez DPH
3201-M3	M3	0,5	56	11	2,2			383
3201-M4	M4	0,7	63	13	2,8	2,1	3	387
3201-M5	M5	0,8	70	16	3,5	2,7	3	387
3201-M6	M6	1	80	19	4,5	3,4	3	426
3201-M7	M7	1	80	19	5,5	4,3	3	675
3201-M8	M8	1,25	90	22	6	4,9	3	478
3201-M10	M10	1,5	100	24	7	5,5	3	588
3201-M11	M11	1,5	100	24	8	6,2	3	1135
3201-M12	M12	1,75	110	29	9	7	3	724
3201-M14	M14	2	110	30	11	9	3	1163
3201-M16	M16	2	110	32	12	9	3	1368

STROJNÍ ZÁVITNÍKY "METRICKÉ" LEVÉ - SLEPÉ VE ŠROUBOVICI DIN371

ocel do 850 N/mm², bronz 700 N/mm², hliník Si < 10% - 600 N/mm²



HSSE 5%Co	DIN 371	C 2-3h	35°	Tol. 6H	α 10° ± 2	L	60°
--------------	------------	-----------	-----	------------	---------------------	---	-----

Material		Vc
Grupo	Sub.	5% Co
1	1.1	6-10
5	5.1	5-8
6	6.1	15-35
	6.2	14-20

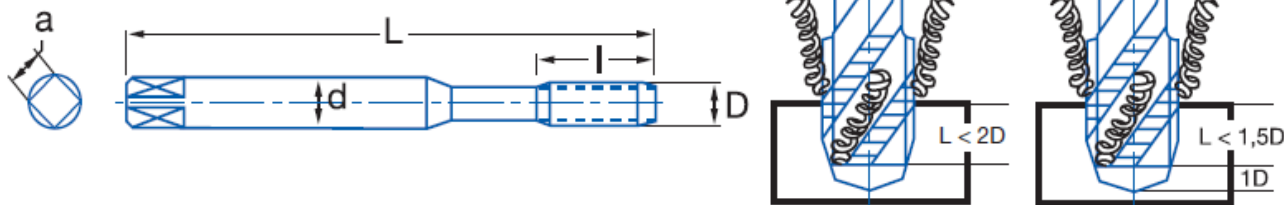

Vc = m/min.

Označení	M	P	L mm	l mm	d mm	a mm	Z	CZK/ks bez DPH
3161-M3	M3	0,5	56	5	3,5	2,7	3	472
3161-M4	M4	0,7	63	7	4,5	3,4	3	472
3161-M5	M5	0,8	70	8	6	4,9	3	450
3161-M6	M6	1	80	10	6	4,9	3	495
3161-M7	M7	1	80	10	7	5,5	3	770
3161-M8	M8	1,25	90	13	8	6,2	3	565
3161-M10	M10	1,5	100	15	10	8	3	670

STROJNÍ ZÁVITNÍKY "METRICKÉ" LEVÉ - SLEPÉ VE ŠROUBOVICI DIN376

ocel do 850 N/mm², bronz 700 N/mm², hliník Si < 10% - 600 N/mm²



HSSE 5%Co	DIN 376	C 2-3h	35°	Tol. 6H	α 10° ± 2	L	60°
--------------	------------	-----------	-----	------------	---------------------	---	-----

Material		Vc
Grupo	Sub.	5% Co
1	1.1	6-10
5	5.1	5-8
6	6.1	15-35
	6.2	14-20

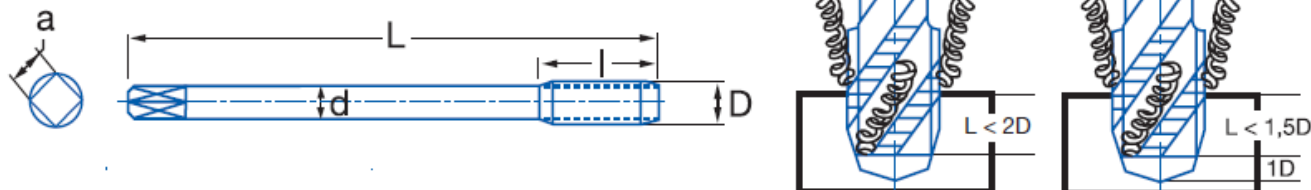

Vc = m/min.

Označení	M	P	L mm	l mm	d mm	a mm	Z	CZK/ks bez DPH
3261-M3	M3	0,5	56	5	2,2			460
3261-M4	M4	0,7	63	7	2,8	2,1	3	456
3261-M5	M5	0,8	70	8	3,5	2,7	3	437
3261-M6	M6	1	80	10	4,5	3,4	3	479
3261-M8	M8	1,25	90	13	6	4,9	3	562
3261-M10	M10	1,5	100	15	7	5,5	3	668
3261-M12	M12	1,75	110	18	9	7	3	859
3261-M14	M14	2	110	20	11	9	3	1348
3261-M16	M16	2	110	20	12	9	4	1629

RUČNÍ SADOVÉ ZÁVITNÍKY "METRICKÉ" LEVÉ

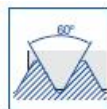

Označení	M	P	L mm	l mm	d mm	a mm	Z	CZK/ks bez DPH
3031-M3	M3	0,5	40	11	3,5	2,7	3	639
3031-M3,5	M3,5	0,6	45	13	4	3	3	751
3031-M4	M4	0,7	45	13	4,5	3,4	3	639
3031-M4,5	M4,5	0,75	50	16	6	4,9	3	1128
3031-M5	M5	0,8	50	16	6	4,9	3	677
3031-M6	M6	1	50	19	6	4,9	3	677
3031-M7	M7	1	50	19	6	4,9	3	827
3031-M8	M8	1,25	56	22	6	4,9	3	827
3031-M9	M9	1,25	63	22	7	5,5	3	1353
3031-M10	M10	1,5	70	24	7	5,5	3	1015
3031-M11	M11	1,5	70	24	8	6,2	3	1691
3031-M12	M12	1,75	75	29	9	7	4	1428
3031-M14	M14	2	80	30	11	9	4	1579
3031-M16	M16	2	80	32	12	9	4	2240
3031-M18	M18	2,5	95	40	14	11	4	2969
3031-M20	M20	2,5	95	40	16	12	4	3345

RUČNÍ SADOVÉ ZÁVITNÍKY "METRICKÉ" JEMNÉ STOUPÁNÍ DIN2181 LEVÉ

ocel do 850 N/mm², bronz 700 N/mm², hliník Si > 10% - 600 N/mm², litina 1000 N/mm²

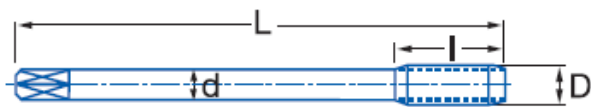
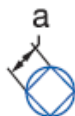

Grupo 1
Subgr. 1.1

Grupo 5
Subgr. 5.1

Grupo 3
Subgr.
3.1/3.2

Grupo 6
Subgr.
6.1/6.2/6.3

HSS

DIN
2181



Tol.
6H



α
10° ± 2

N°1 Desbaste
Roughing
Ebauche

N°3 Acabado
Finishing - Finition
(Ref. 3010)

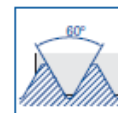

Označení	M	P	L mm	l mm	d mm	a mm	Z	CZK/ks bez DPH
3021-MF8	MF8	1	56	22	6	4,9	3	741
3021-MF10	MF10	1	63	20	7	5,5	3	797
3021-MF10	MF10	1,25	70	24	7	5,5	3	808
3021-MF12	MF12	1,25	70	22	9	7	3	1397
3021-MF12	MF12	1,5	70	22	9	7	3	1191
3021-MF14	MF14	1,25	70	22	11	9	4	1706
3021-MF14	MF14	1,5	70	22	11	9	4	1326
3021-MF16	MF16	1,5	70	22	12	9	4	1659
3021-MF20	MF20	1,5	80	22	16	12	4	2748

ALICON s.r.o. Váš partner v třískovém obrábění

Vápenková 547/4, 147 00 Praha 4, IČ: 28179706, DIČ: C228179706

Tel: +420774317627, Fax: +420227203615, e-mail: info@alicon.cz, www.alicontool.cz